

Neoprene Sponge Profile

Product Code: RC-S083

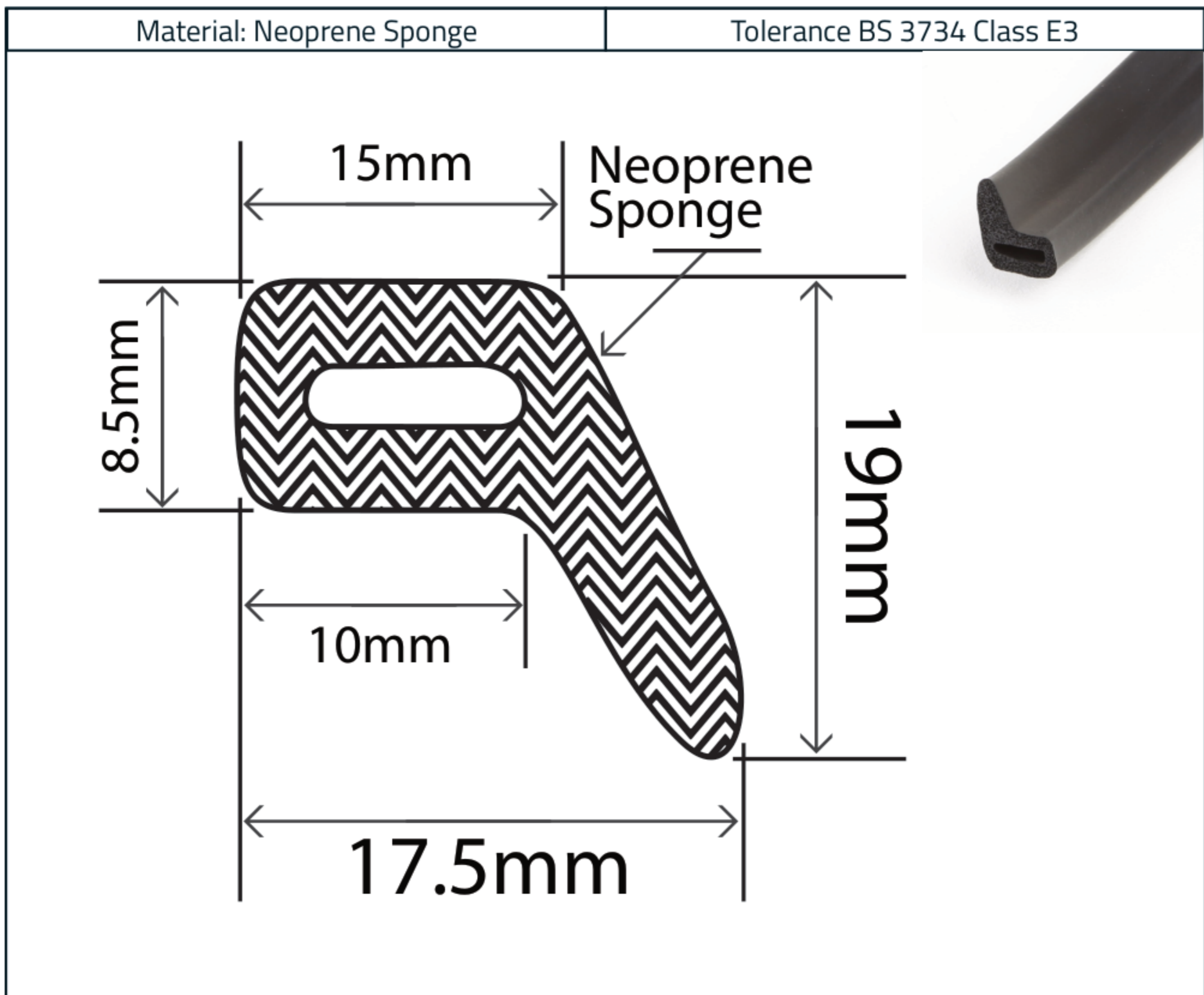

Details:

1. Sold by either the coil or the metre
2. This product's coil length is 50 metres
3. This product's weight per metre is 0.08 kg
4. This product is made of a flexible sponge material therefore sizes are approximations.

The information contained on this product information sheet is to be used as guidance. The advice is given in good faith and does not constitute any guarantee or recommendation for suitability. The Rubber Company cannot be held liable for any damage caused by incorrect installation. We hereby reserve the right to change the technical information herewith without notification or prior agreement.

Technical Data

Specification	Value
Material	Neoprene Sponge
Density Range	0.5 - 0.9 gm/cm ³
Oven Ageing (7 days, 70°C)	±30%
Water Absorption	5% Maximum
Compression (24 hours recovery)	25% Maximum
Oil Swell - Fuel B, 7 days weight change	150% Maximum
Low Temperature Flexibility (-40°C)	Pass
Resistance to Crystallizing	Excellent
Fire Resistance	Good



The information contained on this product information sheet is to be used as guidance. The advice is given in good faith and does not constitute any guarantee or recommendation for suitability. The Rubber Company cannot be held liable for any damage caused by incorrect installation. We hereby reserve the right to change the technical information herewith without notification or prior agreement.